

GRENADIER Plankit planter system



END WALL UNITS

General

The Grenadier Plankit planter system is a cost effective product suitable for creating simple raised planting areas.

The system comprises of wall panels, that are supplied flat-packed to be bolted together on site. If required, corner units can be included as well as angled end sections, to suit the site requirements.

As standard the components are manufactured in FSC Certified treated redwood. As an optional extra walling sections can be supplied in FSC Certified iroko hardwood.

Construction

The End Wall unit comprises of a panel of horizontal 145x45mm section walling slats and are pre-drilled for site assembly. 45x45mm corner fillets are fitted to the ends of the panel.

The inside of the panel is lined with a Terram 1000 geotextile lining, that allows water to drain through whilst retaining the soil fines.

Integral bench seating

If required, optional bench seating can be added to your raised planter. Bexley 4 slat benches can be fitted to the top or side of the planter. As standard the benches are available in 3 lengths.

Optional planter accessories

Tree anchors

25x5mm mild steel flat, hot dip galvanised.

Watering system

Choose either the Street Design reservoir system or the Mona tank system. See Watering System page for full details.

Timber Slatted Screens

Timber slatted screens can be manufactured as an integral part of the planter construction. The side wall unit posts can be extended to facilitate the horizontal 70x32mm section slats.

Street Design Limited

Unit 35
Hayhill Industrial Estate
Barrow upon Soar
Leicestershire LE12 8LD

Contact us:
Telephone: 01509 815335
Fax: 01509 815332
Email: sdl@street-design.com
Web site: www.street-design.com

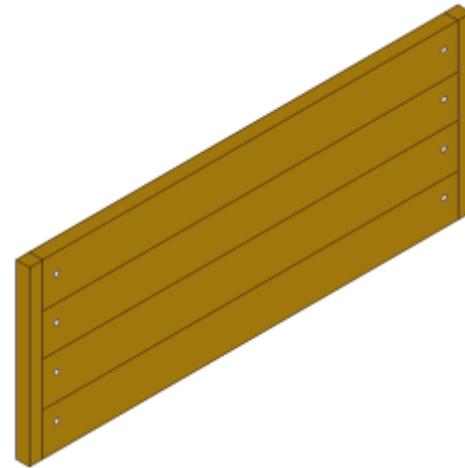

Optional planter accessories

Trellis panels

Trellis panels can be manufactured as an integral part of the planter construction. The corner post can be extended to carry the horizontal and vertical trellis timber slats.

Guarantee

All planters are guaranteed for 15 years minimum. This guarantee is a minimum and is dependant on the product not being misused or abused. All the materials, treatments and construction will allow for a life expectancy considerably longer than this.

General specification

Materials

Hardwood products are constructed using FSC Certified iroko hardwood.
Softwood products are constructed using FSC Certified European redwood.

Treatments

FSC Certified treated softwood will be Wolmanit CX treated, for a desired service life of 30 years minimum.

General specification

FSC Certified iroko hardwood is naturally durable and does not require treatment.

All mild steel fabricated components will be hot dip galvanised after fabrication to BS EN ISO 1461:2009.

All mild steel fixings will be bright zinc plated.

Finishes

FSC Certified treated softwood and iroko hardwood will be left natural to reduce the need for re-staining and help reduce maintenance costs. If required, timber planters can be supplied with a stained finish using 3 coats of quick drying water based wood stain, to the colour of your choice.

Lining

Planter units will be lined with a Terram 1000 geotextile filter fabric lining, which allows the water to drain through the planter, while retaining the fill material.

Product Dimensions

End Wall Unit	Length	Height
KPGRE0505	500mm	580mm
KPGRE1005	500mm	1015mm
KPGRE0510	1000mm	580mm
KPGRE1010	1000mm	1015mm
KPGRE0515	1500mm	580mm
KPGRE1015	1500mm	1015mm

Other lengths and heights can be manufactured to suit your specific area.

Installation

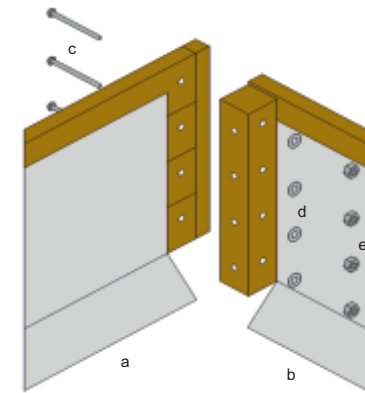

Assembly

Locate End Wall unit (a) in correct position. Position Side Wall unit (b) against End Wall unit ensuring the pre-drilled holes line up. Pass all M12 x 160mm long bolts (c) through the End Wall unit and the 95x95mm post on the Side Wall unit. Fit M12 washers (d) and M12 hex full nuts (e) and tighten. Ensure the assembled units are square and plumb.