



The mark of responsible forestry

'Look for FSC® certified products'



Street Design

Unit 35 Hayhill Industrial Estate Barrow upon Soar Leicestershire LE12 8LD
01509 815335 sdl@street-design.com www.street-design.com

UK Street Furniture Designers & Manufacturers

KENSINGTON planter

The Kensington planter is a timber planter with decorative metal corner straps. It is suitable for a range of applications to suit your requirements. It is available with a choice of material and finishes.

A range of accessories is available to ensure that the Kensington planter is manufactured to suit your specific project.

Kensington planters are suitable for:

- Modular planters
- Tree planters
- Large planters
- Moveable planters
- Planters with integral bench seating

Kensington planter product details

Kensington planter product specification

Kensington planter accessories

Watering system accessories

Adjustable feet accessory

Kensington planter material specification

Kensington planter care and maintenance



Kensington tree planters with Henley planter benches in natural finish FSC®-certified hardwood and galvanised mild steel

KENSINGTON planter

PRODUCT DETAILS

General

The Kensington external planter, is a timber planter, with large top capping and external metal straps, available in a choice of materials and finishes to suit your scheme and budget.

The planter is available in either FSC®-certified hardwood or a FSC®-certified treated European, joinery quality redwood. Planters up to 2.8x2.8m plan size will be delivered fully assembled ready for planting.

Larger planters will be manufactured in sections and delivered for assembly on site.

Other shapes can be manufactured and supplied including hexagonal and octagonal planters.

Planters can be manufactured with additional steel support to enable the planters to be moved when fully planted.

Construction

The Kensington timber planter, is constructed by bolting 45mm thick walling panels to external and internal metal brackets. 95x95mm timbers are fitted into the external corners.

The internal base is constructed using 100x47mm sawn treated softwood bearers, fixed to 95x95mm posts and fitted to joist hangers fixed to the main bearers. FSC®-certified hardwood faced plywood is fixed down onto the bearers. 45mm high timber blocks are fitted to the underside of the bearers, to ensure that the load is safely transferred to the ground.

When fully constructed, the inside of the planter is fully lined with a geo-textile lining, that allows water to drain through whilst retaining the soil fines.



Section thro' planter

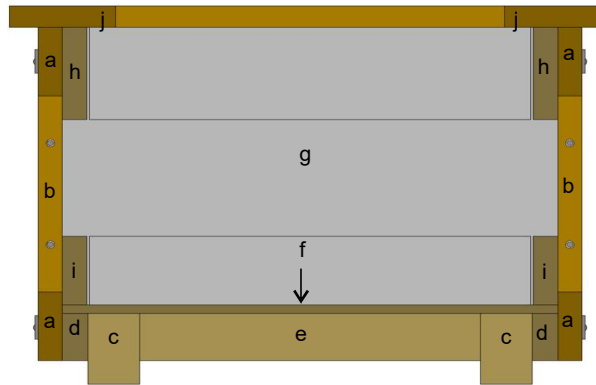

- Key**
- a - 145 x 45mm FSC®-cCertified timber wall slats
 - b - 95x45mm FSC®-certified timber wall slats
 - c - 95 x 95mm FSC®-certified timber corner posts
 - d - 100 x 47mm FSC®-certified timber bearers
 - e - 100 x 47mm FSC®-certified cross bearers
 - f - 18mm FSC®-certified hardwood faced plywood
 - g - Geo-textile membrane filter lining
 - h - 195 x 45mm FSC®-certified treated redwood
 - i - 145 x 45mm FSC®-certified treated redwood
 - j - 195 x 45mm FSC®-certified timber top capping

Typical plan sizes, heights and basic shapes of Kensington planters

Plan dimensions and material options	all other sizes, heights and plan shapes can be manufactured and supplied			
Square	Planter heights			
0.5 x 0.5m	600mm	800mm	1000mm	1200mm
FSC®-certified treated redwood	•	•	•	•
FSC®-certified hardwood	•	•	•	•
1.0 x 1.0m				
FSC®-certified treated redwood	•	•	•	•
FSC®-certified hardwood	•	•	•	•
1.2 x 1.2m				
FSC®-certified treated redwood	•	•	•	•
FSC®-certified hardwood	•	•	•	•
1.5 x 1.5m				
FSC®-certified treated redwood	•	•	•	•
FSC®-certified hardwood	•	•	•	•
2.0 x 2.0m				
FSC®-certified treated redwood	•	•	•	•
FSC®-certified hardwood	•	•	•	•
2.8 x 2.8m				
FSC®-certified treated redwood	•	•	•	•
FSC®-certified hardwood	•	•	•	•
Rectangular	Planter heights			
1.0 x 0.5m	600mm	800mm	1000mm	1200mm
FSC®-certified treated redwood	•	•	•	•
FSC®-certified hardwood	•	•	•	•
2.0 x 1.0m				
FSC®-certified treated redwood	•	•	•	•
FSC®-certified hardwood	•	•	•	•
2.8 x 1.0m				
FSC®-certified treated redwood	•	•	•	•
FSC®-certified hardwood	•	•	•	•

KENSINGTON planter

PRODUCT SPECIFICATION



Unit 35 Hayhill Industrial Estate Barrow upon Soar Leicestershire LE12 8LD
01509 815335 sdl@street-design.com www.street-design.com
UK Street Furniture Designers & Manufacturers

Technical information				
Material				
External timber wall panels comprising of :-	145x45mm and 95x45 FSC®-certified treated redwood or FSC®-certified hardwood			
Internal wall bearers	195x45mm and 145x45 FSC®-certified treated redwood			
External corner detail	95x95mm FSC®-certified treated redwood or FSC®-certified hardwood			
Top timber capping	145x95mm FSC®-certified treated redwood or FSC®-certified hardwood			
External metal brackets	50x5mm mild steel flat or 50x3mm stainless steel			
Internal metal brackets	50x5mm mild steel flat			
Planter posts	95x95mm FSC®-certified treated redwood			
Base bearers	100x47mm FSC®-certified treated redwood			
Base flooring	18mm FSC®-certified hardwood faced plywood			
Fixings	M10 size coachbolts - bright zinc plated			
Standard finish	Natural timber with galvanised mild steel or dull polished stainless steel external straps			
Optional finishes on request	Timber can have a stained finish and the galvanised corner brackets can be polyester powder coated			
Accessories	Adjustable feet Tree anchor fittings Bench seating Watering systems	Trellis panels Metal base frame Pergola structures		
Guarantee	All planters are guaranteed for 15 years			
Walling heights (mm)	600	800	1000	1200
Planting depths (mm)	387	587	787	987
Weights				
Treated redwood planter walls (kgs / lm)	29	37	45	53
Hardwood planter walls (kgs / lm)	52	60	68	76
Planter base (kgs / m ²)	19	19	19	19
Light fill material can be based on:	1000 kgs / m ³			
Heavy fill material can be based on:	2000 kgs / m ³			

Timber policy

All treated softwood planters are manufactured using materials obtained from growers who operate under the Forest Stewardship Council® (FSC®).
All iroko hardwood planters are manufactured using materials obtained from growers who operate under the Forest Stewardship Council® (FSC®).

Construction

All Street Design products are designed and manufactured using only quality, durable materials, construction details and fixings, to provide a long-lasting, durable life expectancy.

Assembly

Planters up to 2.8 x 2.8m will be delivered to site fully assembled for off loading and positioning on site. Planters larger than 2.8m will be supplied in sections for bolting together on site.

Materials

Hardwood planters are constructed from FSC®-certified hardwood, from sustainable sources. Softwood planters are constructed using FSC®-certified redwood that has been pressure treated, for a desired service life of 15 years -in-ground contact. All mild steel fixings will be M12 or M10 size and have a bright zinc plated finish. Planters will be fitted with a geo-textile filter fabric lining, which allows the water to drain through the planter, while retaining the fill material.

Standard finish

FSC®-certified treated softwood and FSC®-certified hardwood will be left natural to reduce the need for re-staining and help reduce maintenance costs.



Large natural finish planters in FSC®-certified hardwood



Square natural finish planters in FSC®-certified hardwood



Large natural finish planters in FSC®-certified treated redwood

Optional finish

Stained finishes are available on request.

Options

Kensington planters are manufactured to order. Before we can manufacture the planters, we need to know the following:

- Plan size and shapes
- Heights
- Material
- Finishes
- Details of accessories required

Accessories

To enhance your Kensington planter and create a product that is suitable for your specific application, you can add from a range of planter accessories.

- Tree anchors
- Adjustable feet
- Watering system
- Internal steel frame
- Pergola structures
- Trellis panels

KENSINGTON planter

ACCESSORIES

Kensington planters can be manufactured and supplied to include a range of optional accessories.

Planters can incorporate; adjustable feet, tree anchor fittings, steel bases, watering systems, bench seating, pergolas and trellis panels.

Adjustable feet

Kensington planters can be manufactured with optional adjustable feet to allow the planter to be height adjusted to ensure that the top of the planter is level. The adjustable feet, allow the planter to be levelled after relocation.

See separate page for Adjustable Feet details.

Watering system

Kensington planters can be supplied with a choice of 2 watering systems. Street Design can supply either a reservoir system, with filler pipe or the Mona, subterranean tank system. See separate page for Watering System details.

Moveable planters

Kensington planters can be supplied with an internal steel base frame to allow the planters to be moved whilst fully planted. The steel frame provides additional strength and ensures suitable supports for the forklift tines.

Pergola structures and trellis panels

By extending the planter posts, pergola structures and trellis panels can be integrated into the planter construction. Pergolas and trellis allow high level planting and create shaded areas for seating.

Tree anchor fittings

Kensington planters can be fitted with galvanised mild steel tree anchor points. They can be fitted at the bottom of the planter to help support the root ball and they can be fitted at the top of the planter to help provide support for the tree. The tree anchors are manufactured using 25x5mm mild steel flat. They have two punched slots and are fitted to the projecting bolt ends on the inside of the planter. The tree anchors are hot dip galvanised.

Bench seating

Integral planter benches, with or without armrests, can be supplied with Kensington planters. As standard 2 bench designs are available. Other designs can be included upon request. The Bexley bench consists of 4 no. 70x45mm timber slats and the Henley bench has 2 no. 145x45mm wide bench slats. The timber slatted benches bolt onto galvanised mild steel brackets, attached to the planter sides. Benches can be fitted to 1, 2, 3 or 4 sides to suit your requirements. The choice of material and finish is the same as for the planter. As standard the brackets will have a galvanised finish. As an optional extra, they can be polyester powder coated.



Kensington planters with optional Henley planter benches with galvanised support brackets



M30 adjustable foot



Kensington planters with optional tree anchor fittings and adjustable feet

Planter bench configurations

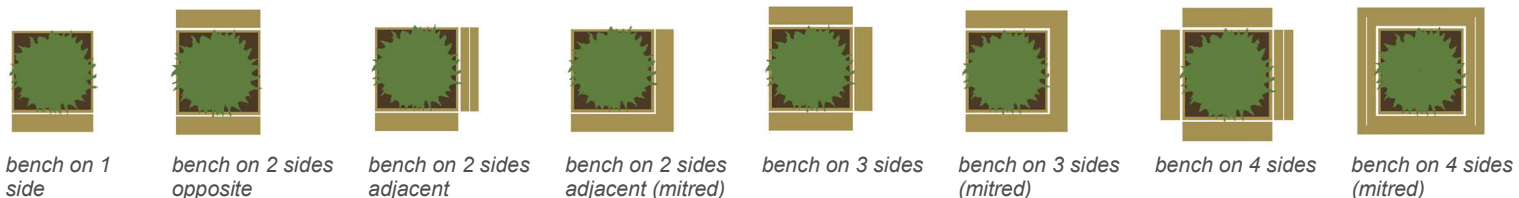

KENSINGTON planter

WATERING SYSTEMS

Watering System 1 - Street Design reservoir system

The Street Design watering accessory is a reservoir system with hydroleca sacks, that maximises the available water.

The system ensures the optimum use of the water and nutrients, delivering the maximum quantity directly to the roots of the plants, resulting in improved root development and optimal plant growth.

General

The system consists of a 300 micron thick black polythene liner, hydroleca (pulverised ash granules) sacks and a rigid plastic filler pipe.

The system delivers water directly to the roots via 50mm diameter, rigid plastic pipe, eliminating water wastage. This encourages deep root growth, improving long term drought resistance. The high level filler pipe provides an easy access point for watering and soluble fertiliser application.

Installation

Planters are supplied with the Water System 1 already installed.

Ensure the hydroleca sacks are in the correct position. They will move during transportation. Check that all the plastic pipe connections are properly fitted. The planter is ready for drainage material, filling and planting.

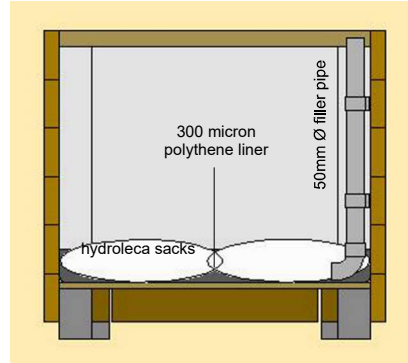

Section thro' planter with Watering System 1



Polythene liner with filler pipe



Hydroleca sacks laid out in base of planter



Unit 35 Hayhill Industrial Estate Barrow upon Soar Leicestershire LE12 8LD
01509 815335 sdl@street-design.com www.street-design.com
UK Street Furniture Designers & Manufacturers

Watering System 2 - MONA subterranean tank system

Mona watering system

Factory fitted into planter / tree container

The Mona Plant System (MPS) is an advanced, well proven and easy to use subterranean irrigation system. It is the cost effective and environmentally friendly solution for both interior and exterior landscaping.

The Mona Plant System ensures that the water and nutrients are delivered in the right quantity to the root of the plants, resulting in improved root development and optimal plant growth.

General

The system consists of storage tanks, flexible linking pipes and a flexible filler pipe with filler pipe cap. The system delivers water directly to the roots via capillary action, eliminating water wastage. This encourages deep root growth, improving long term drought resistance. The cap and lid provides an easy access point for watering and soluble fertiliser application.

Factory installation

All necessary water tanks, pipes, end caps and air pipes with level indicator, are factory fitted into the planters / tree containers, prior to delivery.

Filling planters

Ensure that the distance between the top of the link tank and the lowest part of the root does not exceed 150mm.

For full details visit: www.green-tech.co.uk



Water storage tanks and filler pipe



Planter ready for soil and planting



Completed planter

KENSINGTON planter

ADJUSTABLE FEET

General details

As an extra cost option, Street Design planters can be supplied with adjustable feet. They allow the planter to be levelled, before filling and planting.

Adjustable feet are particularly useful if the planters are likely to be relocated to a new position.

The adjustable foot screw fits into a hex nut, located on the underside of the planter base.

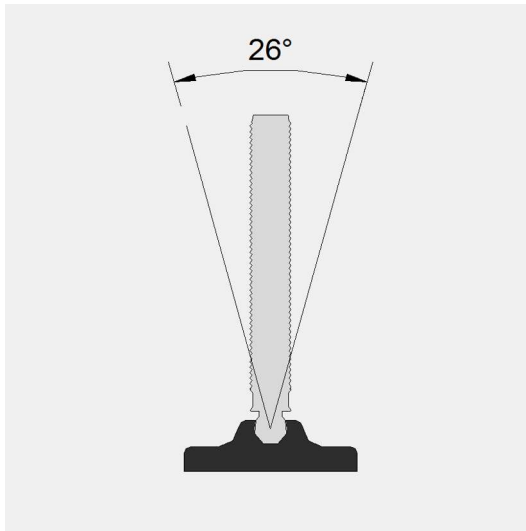

Specification

The adjustable foot comprises of a M30 Ø threaded bar, with spherical end section, press fitted into a black reinforced polyamide base.

The swivel base can tilt through 360° to accommodate sloping ground levels.

The threaded bar is BZP (bright zinc plated) treated.

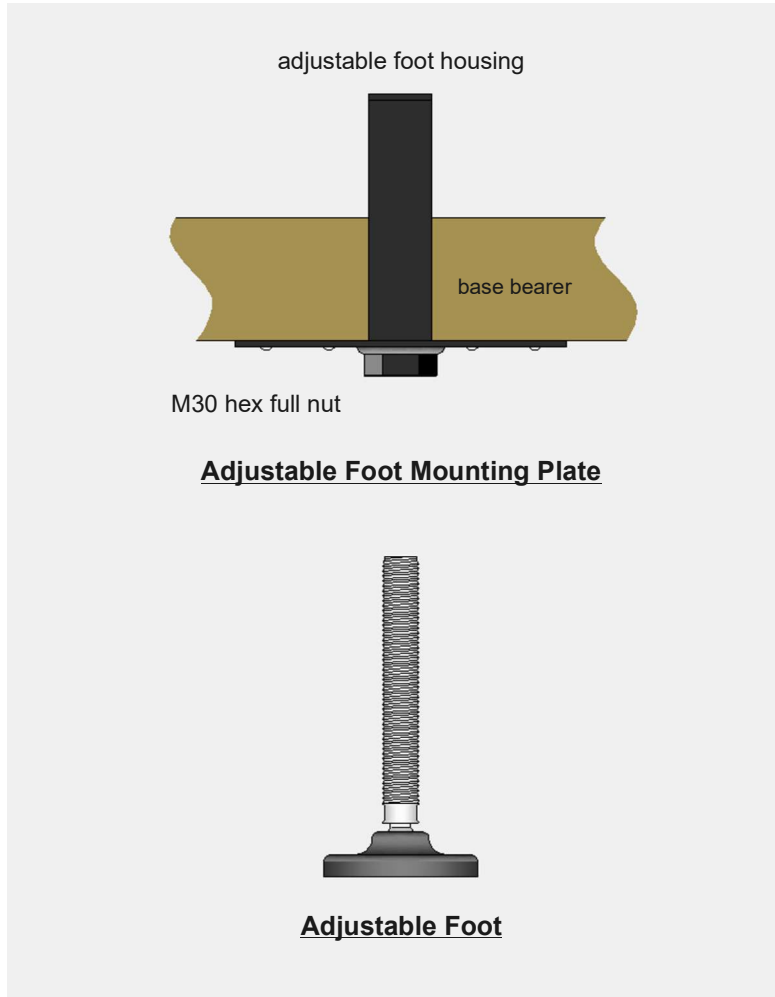

Fitting and adjustment

The M30 adjustable foot with swivel base, is screwed into adjustable foot mounting plate.

The mild steel mounting plate with adjustable foot housing, is fixed to the underside of the planter base.

A M30 hex full nut is welded to the underside of the mounting plate.

The adjustable foot is adjusted with a 26mm wrench.

Base diameter

M30 adjustable foot with swivel base. The base diameter is 122mm.



Swivel base

The swivel base can adjust to allow for sloping ground with a fall of up to 1 in 2.06 (26°).



Bolt down base

For extra security, it is possible to drill and bolt through the base of the adjustable feet.



KENSINGTON planter

MATERIAL SPECIFICATION

Standard planter

Base posts

FSC®-certified 95x95mm FIN PAR pressure treated redwood.

Base bearers

FSC®-certified 100x47mm section pressure treated redwood.

Wall panels

FSC®-certified 145x45 and 95x45mm FIN PAR pressure treated redwood or FSC®-certified hardwood.

Wall panel bearers

FSC®-certified 195x45 and 145x45mm section pressure treated redwood.

External metal corner brackets

Either 50x5mm mild steel flat or 50x3mm grade 304 stainless steel flat.

Internal metal corner brackets

50x5mm mild steel flat.

Base floor

18mm FSC®-certified hardwood faced plywood.

Internal lining

Geo-textile membrane.

Fixing bolts

M10x75mm coach bolts with a BZP finish.

Joist hangers

LUS/230/50 U sheer light nailing hangers with a BZP finish.

Optional planter accessories

Adjustable feet

M30 adjustable feet with swivel base. See Adjustable Foot page for full details.

Tree anchors

25x5mm mild steel flat, hot dip galvanised.

Watering system

Choose either the Street Design reservoir system or the Mona tank system. See Watering System page for full details.

Optional planter accessories continued

Planter benches

Timber bench slats to match planter material in either FSC®-certified treated redwood or FSC®-certified hardwood, bolted to hot dip galvanised mild steel bench brackets.

Moveable planters

Kensington planters can be manufactured with an internal mild steel frame.

Pergola structures

Pergola structures can be manufactured as an integral part of the planter construction. The corner post can be extended to carry the upper horizontal section timber bearers and cross bearers.

Trellis panels

Trellis panels can be manufactured as an integral part of the planter construction. The corner post can be extended to carry the horizontal and vertical trellis timber slats.

Guarantee

All planters are guaranteed for 15 years.

This guarantee is a minimum and is dependant on the product not being misused or abused. All the materials, treatments and construction will allow for a life expectancy longer than this.

Product prices

Contact our Sales Office on 01509 815335 for Kensington planter prices delivered to site.



Street Design

Unit 35 Hayhill Industrial Estate Barrow upon Soar Leicestershire LE12 8LD
01509 815335 sdl@street-design.com www.street-design.com

UK Street Furniture Designers & Manufacturers

General specification

Construction

All Street Design products are designed and manufactured using only quality, durable materials, construction details and fixings, to provide a long-lasting, durable life expectancy.

Assembly

Kensington planters up to 2.8 x 2.8m will be delivered to site fully assembled for off loading and positioning on site. Planters larger than 2.8m will be supplied in sections for bolting together on site.

Timber policy

All treated softwood products are manufactured using materials obtained from growers who operate under the Forest Stewardship Council (FSC®).

All iroko hardwood products are manufactured using materials obtained from growers who operate under the Forest Stewardship Council (FSC®).

Materials

Hardwood products are constructed using FSC®-certified hardwood, from sustainable sources. Softwood products are constructed using FSC®-certified redwood that has been pressure treated, for a desired service life of 15 years -n-ground contact.

All mild steel fabricated components will be hot dip galvanised after fabrication to BS EN ISO 1461:2009.

All stainless steel fabricated components will be grade 304. Grade 316 can be specified if the location or project requires it.

All mild steel fixings will be bright zinc plated, and all stainless steel fixings will be A2 (grade 304). A4 (grade 316) can be specified if the location or project requires it.

Planters will be fitted with a geo-textile filter fabric lining, which allows the water to drain through the planter, while retaining the fill material.

Finishes

FSC®-certified treated softwood and FSC®-certified hardwood will be left natural to reduce the need for re-staining and help reduce maintenance costs.

Optional stained finish available on request.

Mild steel components will be left with a galvanised finish only. If required, after hot dip galvanising, the mild steel components can be polyester powder coated, to the colour of your choice. The galvanised parts are prepped, treated and sprayed with the polyester powder, before being baked in an oven.

Stainless steel components will have a dull polished (brushed) finish. If required, the stainless steel components can be supplied with a mirror polished or bead blasted finish.

KENSINGTON planter

CARE & MAINTENANCE



Unit 35 Hayhill Industrial Estate Barrow upon Soar Leicestershire LE12 8LD
01509 815335 sdl@street-design.com www.street-design.com
UK Street Furniture Designers & Manufacturers

General

All Kensington planter products are manufactured using quality materials, treatments and finishes. The timber slats are manufactured from either FSC®-certified treated redwood or FSC®-certified hardwood. The mild steel will be hot dip galvanised after fabrication. The stainless steel will be supplied with a dull polished (brushed) finish. All products require a varied amount of maintenance, depending on the environment, usage and weather conditions. Natural timber, galvanised steel and stainless steel will only require cleaning. In time, stained timber will require re-coating.

Maintaining the standard FSC®-certified treated redwood finish

Natural finish treated redwood can be washed down with a mild detergent. More stubborn surface marks can be removed with a light, hand sand with a 120 grit, or higher grade sandpaper. Excessive sanding should be avoided.



Maintaining the optional FSC®-certified treated redwood finish

Stained, treated redwood will need to be re-coated after a period of time. The stain can either start to fade, become dull (oxidised) or incur some surface break up. Lightly sand down the timber using a 120 grit, or higher grade sandpaper. We recommend that the timber is re-stained with the original stain colour and manufacturer. Details can be obtained from Street design Limited. Apply the stain evenly, with brush strokes running parallel with the woodgrain, in thin layers, building up the finish as recommended by the stain manufacturer.

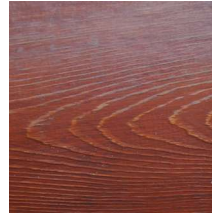

Maintaining the standard FSC®-certified hardwood finish

Natural finish hardwood can be washed down with a mild detergent. More stubborn surface marks can be removed with a light, hand sand with a 120 grit, or higher grade sandpaper. Excessive sanding should be avoided.



Maintaining the optional FSC®-certified hardwood finish

Stained hardwood will need to be re-coated after a period of time. The stain can either start to fade, become dull (oxidised) or incur some surface break up. Lightly sand down the timber using a 120 grit, or higher grade sandpaper. We recommend that the timber is re-stained with the original stain colour and manufacturer. Details can be obtained from Street design Limited. Apply the stain evenly, with brush strokes running parallel with the woodgrain, in thin layers, building up the finish as recommended by the stain manufacturer.



Maintaining the standard mild steel finish

Hot dip galvanised mild steel is a very durable and hard wearing finish. Dirt can be washed off with warm water and a mild detergent. Always use clean water and cleaning cloths to avoid surface contamination. After cleaning, any severe marks can be over painted with a cold galvanised, (zinc rich) aerosol spray.



Maintaining the optional mild steel finish

Polyester powder coated finishes should be washed down with clean warm water and a mild detergent. Minor touching up can be done with an aerosol to match the original powder coated colour. Details can be obtained from Street Design Limited. More severe damage can be repaired by sanding down, by manual or mechanical means, beyond the damaged area, sufficiently far as to ensure that any step in the powder coated finish is removed. This will ensure that after re-finishing the repair will be difficult to detect.



Maintaining the standard stainless steel finish

Dull polished (brushed) stainless steel should be washed down with clean, warm water with a mild detergent. More severe marks can be removed by using a fine abrasive, such as a Scotchbrite or stainless steel scouring pad. As dull polishing is a process of applying fine linear scratches evenly over the surface, it is extremely important that rubbing down with an abrasive pad is done carefully in a straight line parallel to the existing grained finish. Rust marks or stains are usually caused by environmental contamination from dissimilar materials laid against, or near to, the stainless steel. These stains can be removed as described above.

